

MOVING YOU FURTHER



HYUNDAI
CONSTRUCTION EQUIPMENT

SPECIAL PRODUCT LINE

HYUNDAI CONSTRUCTION EQUIPMENT



PLEASE CONTACT

www.hyundai-ce.com

2019. 03 Rev.0

HYUNDAI
CONSTRUCTION EQUIPMENT

SPECIAL PRODUCT LINE

HYUNDAI CONSTRUCTION EQUIPMENT

Solution for Total Construction

We provide several machines with wide range of model choice. We provide not only machines but also human to hear your voice. From 1.6 ton to 120 ton excavators with wheel loaders, We provide total solution with special product in this time.

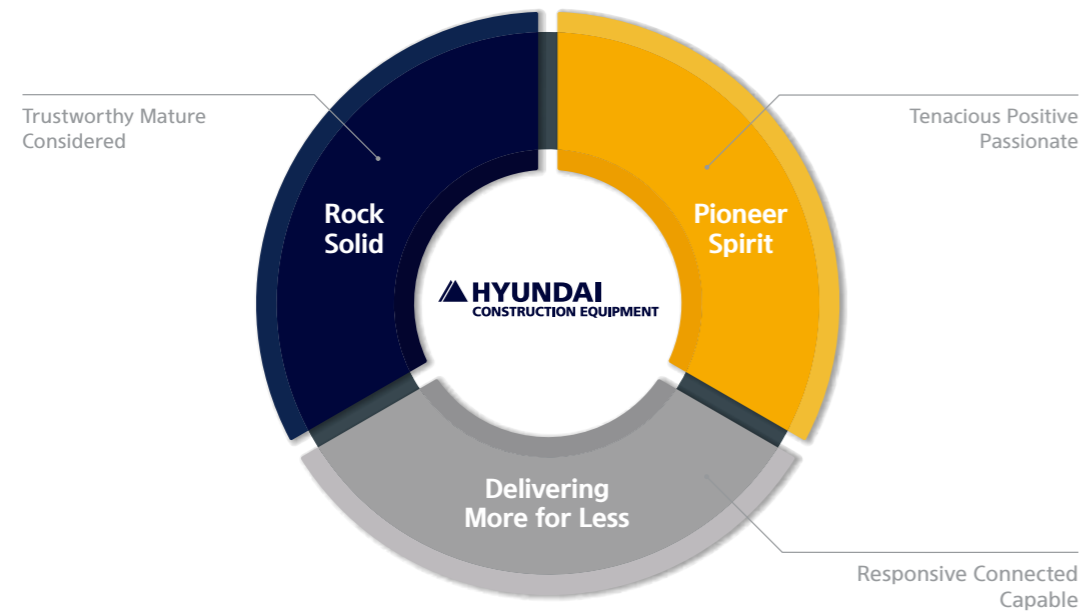

World Class - Advanced Base to be Your Side

For fast speed on service in time during your operation, We have several base of HYUNDAI with thousand of dealers over the world. With current standard machines of HYUNDAI network, Special product will give you the great satisfaction.

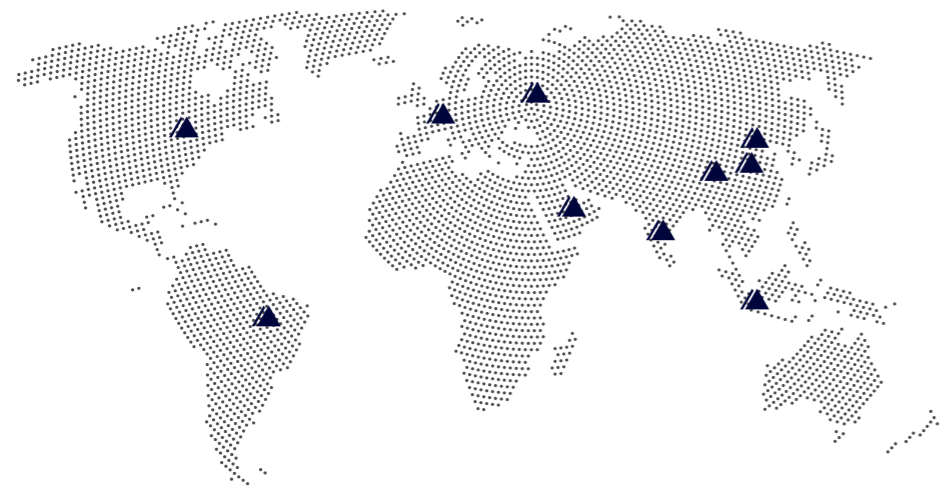

MOVING YOU FURTHER,
MAKE THE FIRST STEP

R380LC-9 DM DEMOLITION



TO BE THE REAL -
CONSTRUCTION SOLUTION

R210W-9 MH

MATERIAL HANDLER



SPECIAL PRODUCT LINE

9, 9S, 9SH Series : Tier-2, 3 / Stage-3A Area Model
ex. Brazil, South America, Russia, Singapore, etc

HX, HW Series : Tier-4 Final / Stage-4 Area Model
ex. Korea, North America, Europe, etc

WASTE & RECYCLING

MH MATERIAL HANDLER



Model	Max. Reach	Max. Height
R210W-9,9S	11.0 m	12.2 m
R300LC-9,9S	13.0 m	14.3 m
R380LC-9,9SH (2 Piece Front)	14.4 m	15.5 m
R380LC-9,9SH (3 Piece Front)	14.1 m	15.4 m
R480LC-9,9S (2 Piece Front)	16.8 m	18.1 m
R480LC-9,9S (3 Piece Front)	16.4 m	17.9 m

BUILDING & SUBWAY

TS TELESCOPIC DIPPER



Model	Max. Depth / Max. Height	Clamshell
R220LC-9,9S	21.0 m / 5.6 m	0.6 m ³
R260LC-9,9S	23.0 m / 5.7 m	0.8 m ³
R300LC-9,9S	25.0 m / 5.1 m	1.0 m ³
R380LC-9,9SH	30.0 m / 5.7 m	1.4 m ³
R480LC-9,9S (Normal)	30.0 m / 6.2 m	1.7 m ³
R480LC-9,9S (Dipper Version)	34.0 m / 6.6 m	1.5 m ³

MINING & STONE

FS FRONT SHOVEL



Model	Dump. Height / Digging Reach	Recommended Bucket Capa.
R380LC-9,9SH	7.1 m / 8.5 m	1.8 m ³
	4.7 m / 8.5 m	2.0 m ³
R480LC-9,9S	7.3 m / 8.7 m	2.2 m ³
	4.3 m / 8.7 m	2.4 m ³
R520LC-9,9S	7.3 m / 8.7 m	2.6 m ³
	4.3 m / 8.7 m	2.8 m ³
R850LC-9	7.6 m / 9.5 m	4.0 m ³

RAILROAD

RG RAIL GUIDE



Model	Features
R55W-9A	Perform Earth Work on a Rail Road
R60W-9S	Installed Rail Guide Axle for Both Direction

BUILDING REQUIDATION

DM HIGH REACH DEMOLITION



Model	Max. Reach / Max. Height	Allowable Tool Weight
R220LC-9,9S (2 Piece Front)	8.3 m / 14.6 m	2.0 ton
R220LC-9,9S (3 Piece Front)	8.6 m / 14.9 m	2.0 ton
R260LC-9,9S (3 Piece Front)	9.8 m / 16.1 m	2.0 ton
R300LC-9,9S (3 Piece Front)	10.3 m / 18.0 m	2.0 ton
R380LC-9,9SH (3 Piece Front)	13.0 m / 21.0 m	2.2 ton
R480LC-9,9S (3 Piece Front)	14.5 m / 25.0 m	2.6 ton
R520LC-9,9S (3 Piece Front)	15.3 m / 28.0 m	2.2 ton
R850LC-9	20.0 m / 35.0 m	3.0 ton

HARBOR & TRENCH

LR SUPER LONG REACH



Model	Max. Digging Reach	GP / Ditch Bucket Capa.
R140LC-9,9S	12.0 m	0.28 / 0.28 m ³
R180LC-9,9S	13.5 m	0.35 / 0.39 m ³
R220LC-9,9S	15.3 m	0.40 / 0.45 m ³
R260LC-9,9S	16.8 m	0.40 / 0.51 m ³
R300LC-9,9S	18.4 m	0.45 / 0.51 m ³
R330LC-9,9S	18.4 m	0.45 / 0.51 m ³
R380LC-9,9SH	18.4 m	0.66 / 0.66 m ³
R430LC-9,9SH	19.7 m	0.92 / 0.66 m ³
R480LC-9,9S	19.7 m	0.92 / 0.66 m ³
R520LC-9,9S	19.7 m	0.92 / 0.66 m ³
R850LC-9	27.4 m	1.25 / 1.24 m ³

FOREST

LL LOG LOADER



Model	Max. Reach	Max. Height	Overall Width
R290LC-9	9.1 m	9.6 m	3,470 mm

SPECIAL PRODUCT LINE

9, 9S, 9SH Series : Tier-2, 3 / Stage-3A Area Model
ex. Brazil, South America, Russia, Singapore, etc

HX, HW Series : Tier-4 Final / Stage-4 Area Model
ex. Korea, North America, Europe, etc

WOOD HANDLING

LG LOADER LOG GRAPPLE



Model	Tropical Type Height / Length / Width	General Purpose Height / Length / Width	Sorting Type Height / Length / Width
HL740-9,9S	1.6 m 1.3 / 1.8 m	1.8 m 1.0 / 1.8 m	2.0 m 1.0 / 1.6 m
HL757-9,9S	1.7 m 1.4 / 2.3 m	2.2 m 1.3 / 1.9 m	2.2 m 1.2 / 1.7 m
HL760-9,9S	1.9 m 1.4 / 2.5 m	2.4 m 1.4 / 1.9 m	2.6 m 1.2 / 1.9 m
HL770-9,9S	2.4 m 1.6 / 2.7 m	2.4 m 1.4 / 2.0 m	2.9 m 1.3 / 1.9 m
HL780-9,9S	2.5 m 1.7 / 3.0 m	2.7 m 1.5 / 2.0 m	2.9 m 1.3 / 2.0 m

WASTE & RECYCLING

MH MATERIAL HANDLER



Model	Max. Reach	Max. Height
HW210 MH	11.0 m	12.2 m
HX300 MH	13.0 m	14.3 m
HX380 MH (2 Piece Front)	14.4 m	15.5 m
HX380 MH (3 Piece Front)	14.1 m	15.4 m
HX480 MH (2 Piece Front)	16.8 m	18.1 m
HX480 MH (3 Piece Front)	16.4 m	17.9 m

BUILDING & SUBWAY

TS TELESCOPIC DIPPER



Model	Max. Depth / Max. Height	Clamshell
HX220 TS	21.0 m / 5.6 m	0.6 m ³
HX260 TS	23.0 m / 5.7 m	0.8 m ³
HX300 TS	25.0 m / 5.1 m	1.0 m ³
HX380 TS	30.0 m / 5.7 m	1.4 m ³
HX480 TS (Normal)	30.0 m / 6.2 m	1.7 m ³
HX480 TS (Dipper Version)	34.0 m / 6.6 m	1.5 m ³

FORK LIFTING

PF LOADER PALLET FORK



Model	Operating Width (A) / Tine Size (Length / Width / Thickness)
HL740-9,9S	450-2,030 mm 1,500 / 150 / 60 mm
HL757-9,9S	450-2,030 mm 1,800 / 180 / 70 mm
HL760-9,9S	600-2,160 mm 1,800 / 180 / 70 mm
HL770-9,9S	600-2,160 mm 1,800 / 200 / 95 mm
HL780-9,9S	600-2,160 mm 1,800 / 200 / 95 mm

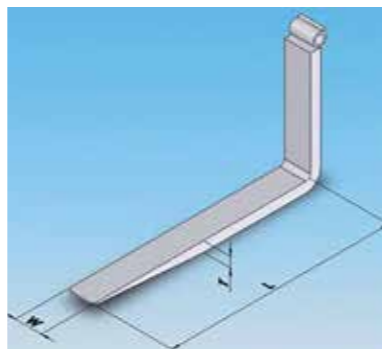
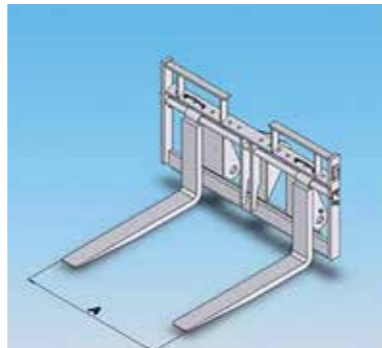

BUILDING REQUIDATION

DM HIGH REACH DEMOLITION



Model	Max. Reach / Max. Height	Allowable Tool Weight
HX220 DM (2 Piece Front)	8.3 m / 14.6 m	2.0 ton
HX220 DM (3 Piece Front)	8.6 m / 14.9 m	2.0 ton
HX260 DM (3 Piece Front)	9.8 m / 16.1 m	2.0 ton
HX300 DM (3 Piece Front)	10.3 m / 18.0 m	2.0 ton
HX380 DM (3 Piece Front)	13.0 m / 21.0 m	2.2 ton
HX480 DM (3 Piece Front)	14.5 m / 25.0 m	2.6 ton
HX520 DM (3 Piece Front)	15.3 m / 28.0 m	2.2 ton
HX900 DM	20.0 m / 35.0 m	3.0 ton

HARBOR & TRENCH

LR SUPER LONG REACH



Model	Max. Digging Reach	GP / Ditch Bucket Capa.
HX140 LR	12.0 m	0.28 / 0.28 m ³
HX160 LR	13.5 m	0.35 / 0.39 m ³
HX220 LR	15.3 m	0.40 / 0.45 m ³
HX260 LR	16.8 m	0.40 / 0.51 m ³
HX300 LR	18.4 m	0.45 / 0.51 m ³
HX380 LR	18.4 m	0.66 / 0.66 m ³
HX480 LR	19.7 m	0.92 / 0.66 m ³
HX520 LR	19.7 m	0.92 / 0.66 m ³
HX900 LR	27.4 m	1.25 / 1.24 m ³

SPECIAL PRODUCT LINE

9, 9S, 9SH Series : Tier-2, 3 / Stage-3A Area Model
ex. Brazil, South America, Russia, Singapore, etc

HX, HW Series : Tier-4 Final / Stage-4 Area Model
ex. Korea, North America, Europe, etc

MINING & STONE

FS FRONT SHOVEL



Model	Dump. Height / Digging Reach	Recommended Bucket Capa.
HX380 FS	7.1 m / 8.5 m	1.8 m ³
	4.7 m / 8.5 m	2.0 m ³
HX480 FS	7.3 m / 8.7 m	2.2 m ³
	4.3 m / 8.7 m	2.4 m ³
HX520 FS	7.3 m / 8.7 m	2.6 m ³
	4.3 m / 8.7 m	2.8 m ³
HX900 FS	7.6 m / 9.5 m	4.0 m ³

RAILROAD

RG RAIL GUIDE



Model	Features
HW60	Perform earth work on a rail road Installed Rail Guide Axle for both direction

KOREA MARKET ONLY

ELECTRIC EXCAVATOR



Model	Rated Power	Weight
R300LC-E	218 ps / 1,785 rpm	30.0 ton
HX380E	300 ps / 1,785 rpm	41.5 ton

FOREST

LL LOG LOADER



Model	Max. Reach	Max. Height	Overall Width
HX300 LL	9.1 m	9.6 m	3,470 mm

WOOD HANDLING

LG LOADER LOG GRAPPLE



Model	Tropical Type Height / Length / Width	General Purpose Height / Length / Width	Sorting Type Height / Length / Width
HL940 LG	1.6 m 1.3 / 1.8 m	1.8 m 1.0 / 1.8 m	2.0 m 1.0 / 1.6 m
HL955 LG	1.7 m 1.4 / 2.3 m	2.2 m 1.3 / 1.9 m	2.2 m 1.2 / 1.7 m
HL960 LG	1.9 m 1.4 / 2.5 m	2.4 m 1.4 / 1.9 m	2.6 m 1.2 / 1.9 m
HL970 LG	2.4 m 1.6 / 2.7 m	2.4 m 1.4 / 2.0 m	2.9 m 1.3 / 1.9 m
HL980 LG	2.5 m 1.7 / 3.0 m	2.7 m 1.5 / 2.0 m	2.9 m 1.3 / 2.0 m

FORK LIFTING

PF LOADER PALLET FORK



Model	Operating Width (A) / Tine Size (Length / Width / Thickness)
HL940 PF	450-2,030 mm 1,500 / 150 / 60 mm
HL955 PF	450-2,030 mm 1,800 / 180 / 70 mm
HL960 PF	600-2,160 mm 1,800 / 180 / 70 mm
HL970 PF	600-2,160 mm 1,800 / 200 / 95 mm
HL980 PF	600-2,160 mm 1,800 / 200 / 95 mm

